

DEFT – 1

EMERGENCY LOCATOR TRANSMITTER INSTRUCTION AND MAINTENANCE MANUAL

**EMERGENCY BEACON CORPORATION
15 RIVER STREET
NEW ROCHELLE, NEW YORK 10801
Phone: (914) 235-9400 / 576-2700
Fax: (914) 576-7075
E-mail: emergencybeacon@sprynet.com
Web: www.emergencybeaconcorp.com**

Revision 02
January 2003

Revision Record

<u>Date</u>	<u>Page</u>	<u>Revision</u>
October 15, 1998	All pages	Manual Revised
January 1, 2003	Cover, page 12, & Warranty Sheet	References to ELT's Unlimited Inc., replaced by Emergency Beacon Corp.

TABLE OF CONTENTS

SECTION 1
GENERAL DESCRIPTION4

SECTION 2
DESCRIPTION OF TOGGLE SWITCH POSITIONS.....5

SECTION 3
ELT INSTALLATION5

SECTION 4
ANTENNA INSTALLATION7

SECTION 5
FINAL INSTALLATION AND TEST7

SECTION 6
HELICOPTER INSTALLATION.....7

SECTION 7
DESCRIPTION OF REMOTE SWITCH POSITIONS8

SECTION 8
REMOTE SWITCH KIT INSTALLATION8

SECTION 9
OPERATING INSTRUCTIONS.....9

SECTION 10
PERIODIC MAINTENANCE.....9

SECTION 11
BATTERY REPLACEMENT10

SECTION 12
REPAIRS AND SHIPPING INSTRUCTIONS12

SECTION 13
SPECIFICATIONS.....12

WARRANTY AND REGISTRATION FORM13

**SECTION 1
GENERAL DESCRIPTION**

The DEFT-1 is an automatically activated Emergency Locator Transmitter (ELT.) It may be manually activated using its toggle switch or via the optional remote switch. It will simultaneously radiate an omnidirectional signal on 121.5 MHz and 243.0 MHz. The DEFT-1 is buoyant and will float in an upright position with the antenna extended. It is Type Accepted by the FCC under Part 87.

The following is a list of the basic parts and accessories used with the DEFT-1.

<u>Description</u>	<u>Part Number</u>
<u>Basic System</u>	
Transmitter "A" Configuration OR Transmitter "B" Configuration	05 01 108A 05 01 108B
Mounting Tray	05 02 002
Coaxial Cable 44"	05 03 002A
External Antenna	05 04 002
Collapsible Portable Antenna Kit	05 06 002
Battery Pack	05 07 002B
<u>Accessories</u>	
Coaxial Cable 75"	05 03 002B
Coaxial Cable 140"	05 03 002C
Portable Whip Antenna	05 05 002
Remote Switch Kit	05 08 002

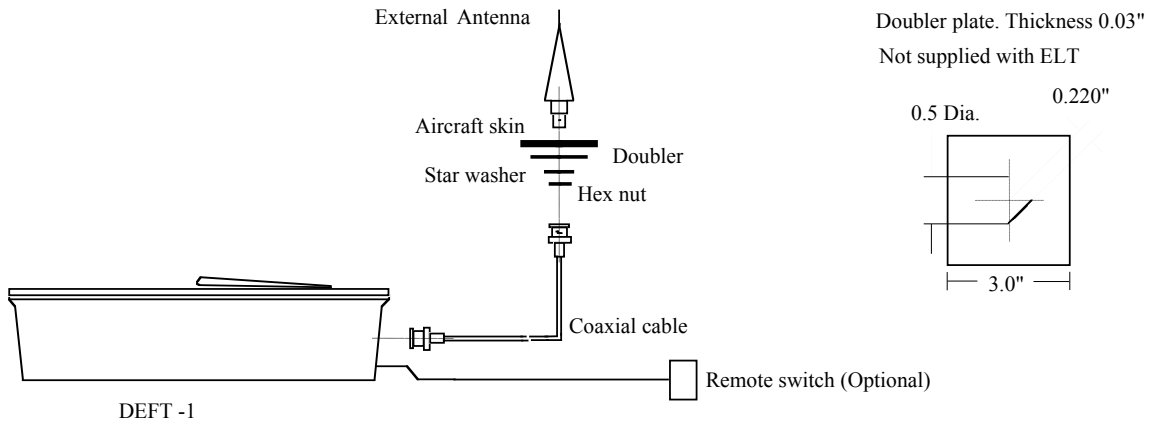

SYSTEM COMPONENTS

SECTION 2

DESCRIPTION OF TOGGLE SWITCH POSITIONS

The DEFT-1 switch is the locking type and requires that the bat handle be lifted before its position can be changed.

The **ON** position is used to manually activate the ELT in an emergency.

The **OFF** position is used when the ELT is removed from the aircraft for maintenance or shipping.

The **ARM** position is used for normal flight operations.

TO RESET THE DEFT-1, SET THE TOGGLE SWITCH TO THE **OFF** POSITION AND THEN BACK TO THE **ARM** POSITION.

SECTION 3

ELT INSTALLATION

The DEFT-1 ELT system is composed of a transmitter, mounting tray/bracket, coaxial cable, antenna and an optional remote switch. Improper installation of any of these components can result in poor performance or non-operation. When selecting a location for installation, make a survey of the available space, pathways, and airframe area needed to mount the ELT, run of coaxial cable, and antenna. Take into account the following:

- ∞ Mount the ELT and external antenna as close to each other as possible and practical. (The distance between them should not exceed 40 inches.)
- ∞ The external antenna, ELT and coaxial cable should be mounted between the same two bulkheads.
- ∞ If the antenna is to be mounted on a non-metallic surface, a supplementary ground plane must be installed.
- ∞ Mount the ELT as far aft as possible and near an inspection access panel. Allow accessibility for maintenance and the possible need for portable operation.
- ∞ The location chosen to install the ELT must provide rigidity and must not be subject to vibration that could cause activation.
- ∞ The transmitter controls must be accessible for manual activation and deactivation.
- ∞ The Direction of Flight arrow must face forward and be aligned with the longitudinal axis of the aircraft within +/- 10 degrees.

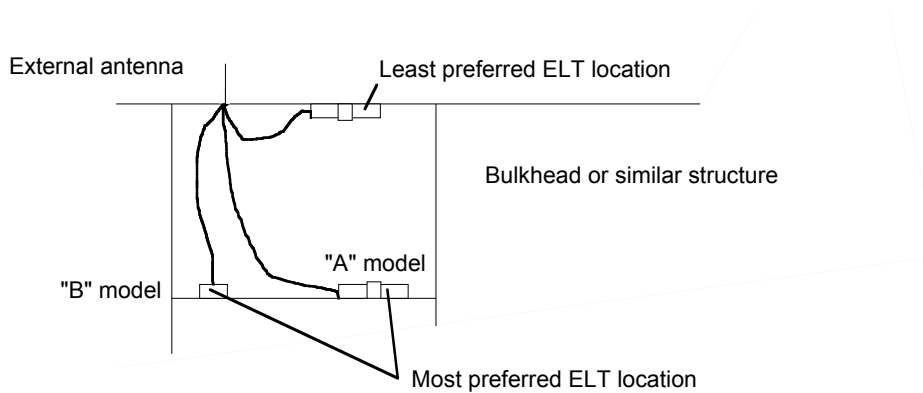

TRANSMITTER LOCATION FOR FIXED WING AIRCRAFT

- ∞ Use the mounting tray/bracket as a template to mark out the holes needed for installation.
- ∞ When choosing a location for the mounting tray remember that it is keyed, and the ELT can only be mounted one way. Make certain that the mounting tray is installed so that the Direction of Flight arrow is parallel to within 10 degrees of the longitudinal axis of the aircraft.
- ∞ The DEFT-1 can be installed on horizontal or vertical surfaces as long as the Direction of Flight arrow is parallel to within 10 degrees of the longitudinal axis of the aircraft.
- ∞ Attach the mounting tray/bracket using accepted procedures. It must be secured to a rigid member of the aircraft so that a force of 100 lbs. applied to it will not cause a movement greater than $\frac{1}{4}$ inch.
- ∞ Install so that all the requirements of FAR 91.52 and FAR 23 or FAR 25 are met.
- ∞ Mount the tray/bracket using fasteners that comply with FAR 23.561 or FAR 25.561.
- ∞ Do not install the mounting tray/bracket to thin unsupported skin.

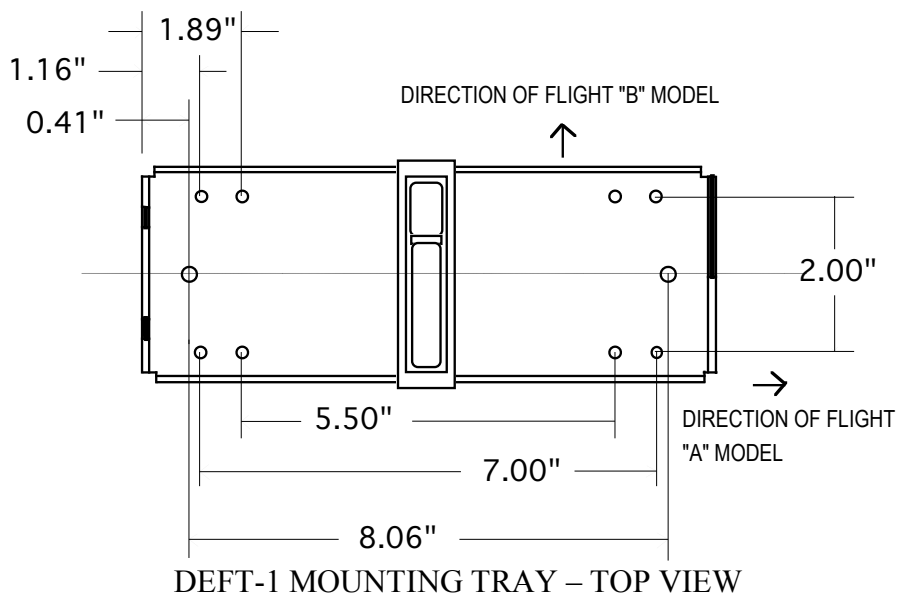

SECTION 4 ANTENNA INSTALLATION

Mount as far aft as practical and a minimum of 2 feet from any VHF communications antennas. It should not foul other antennas in flight. The antenna should be mounted as close as possible to the transmitter.

Drill a ½" diameter hole at the desired mounting locations. A doubler plate should be fabricated if needed.

If the antenna is being installed on a non-metallic surface, a supplementary ground plane must be installed. Install the antenna using supplied hardware.

SECTION 5 FINAL INSTALLATION AND TEST

Before the DEFT-1 is installed into its mounting tray/bracket, perform the following tests. It is recommended that such tests receive prior approval of the nearest control tower. FAA and FCC regulations require that transmitter tests be performed only during the first 5 minutes of each hour and last no longer than 3 audio sweeps.

DO NOT ACTIVATE THE TRANSMITTER UNTIL YOU THOROUGHLY UNDERSTAND HOW TO DEACTIVATE IT!

Set communications receiver or portable radio to 121.5 MHz.

Place toggle switch in the **ON** position. The distinctive ELT swept tone should be heard over the radio receiver.

To deactivate the unit, move the switch to the **OFF** position.

Test the auto activation circuitry by placing the toggle switch in the **ARM** position and subjecting the ELT to a quick forward snap in the direction of the arrow, followed by a rapid reversing motion. The distinctive audio sweep should be heard over the radio.

Deactivate the ELT by placing the toggle switch in the **OFF** position.

Install the ELT onto its mounting tray. Attach the coaxial cable to the ELT and the antenna. Secure the coax using standard practices. Again perform the basic test to verify system operation.

Due to the extreme sensitivity of aircraft COM radios, an ELT radiating very little power due to a fault within the ELT, coax cable or antenna can be received on the COM as a good ELT signal. Therefore, it is recommended that the receiver be tuned to another frequency such as 121.600 MHz. Activate the ELT; a strong signal should bleed through and be heard.

SECTION 6 HELICOPTER INSTALLATION

The methods used for installation in a helicopter are the same as those used on a fixed wing except that the ELT is mounted with the Direction of Flight arrow facing forward and downward at a 45-degree angle with respect to the longitudinal axis of the helicopter.

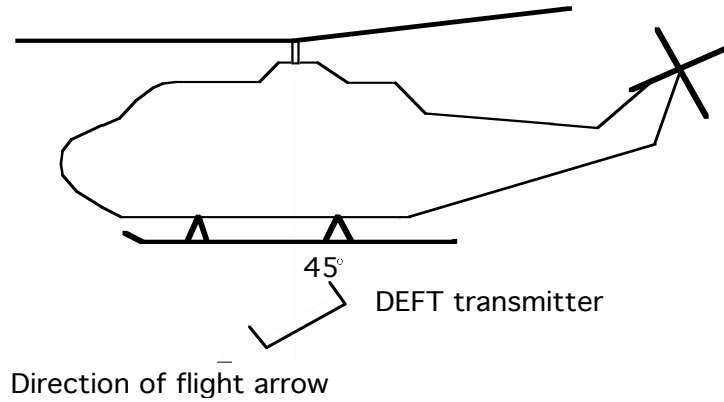

**SECTION 7
DESCRIPTION OF REMOTE SWITCH POSITIONS**

The remote switch allows the pilot to activate and reset the ELT from the cockpit.

NOTE: The remote switch does not override the ELT switch. Remember to set the ELT toggle switch to the **ARM** position. The ELT will not automatically activate with the remote switch in the **ARM** position if the ELT's switch is in the **OFF** position.

The **ARM** position is used for normal flight operations.

The **ON** position is used to manually activate the ELT.

TO RESET THE DEFT-1 WHEN USING A REMOTE SWITCH, SET THE REMOTE SWITCH TO THE **ON** POSITION AND THEN BACK TO THE **ARM** POSITION.

**SECTION 8
REMOTE SWITCH KIT INSTALLATION**

If a pilot's remote switch is used, connect the two #20 AWG wires from the mini plug to the two-position guarded switch included in the remote switch kit.

Use shielded twisted pair cable where electrical interference is high.

Set the remote switch to the **ARM** position.

Plug the mini plug into the ELT jack and install the remote switch in a convenient place on the instrument panel. See below:

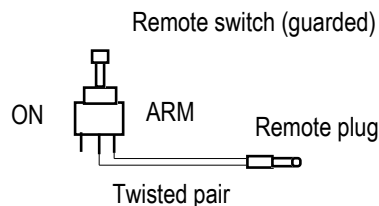

REMOTE SWITCH WIRING\

SECTION 9 OPERATING INSTRUCTIONS

The DEFT-1 is for aviation emergency use only. In an accident with sufficient G-forces along the longitudinal axis of the aircraft, the ELT is automatically activated. The ELT can be manually activated by setting the **ON-OFF-ARM** switch on the transmitter to the **ON** position or setting the remote switch on the instrument panel to **ON**.

If possible after an accident, inspect the external antenna for damage. If it becomes necessary to remove the ELT from the aircraft, remove the large BNC connector by pushing it in and turning counterclockwise, then pulling it out. If the transmitter has a remote switch plug, just pull it out.

Remove the ELT from its mounting tray/bracket by releasing the latch on the strap and lifting the ELT off the tray.

Attach the optional portable collapsible antenna and extend it to its full length.

Place the ELT on high ground with the antenna in a vertical position. If using at temperatures below freezing, for the longest operating life keep the transmitter inside a jacket with the antenna outside.

ADD THE ELT TO YOUR PREFLIGHT AND POSTFLIGHT CHECKLIST

PREFLIGHT:

Inspect the antenna, connections, and unit installation.

Test for normal operations by listening with the aircraft COM receiver.

Check that the ELT's manual switch and/or remote switch is in the **ARM** position before flight.

POSTFLIGHT:

Check that the ELT's manual switch and/or remote switch is set to **ARM**.

Tune a COM radio to 121.5 MHz and listen for the ELT signal.

SECTION 10 PERIODIC MAINTENANCE

THESE INSPECTION PROCEDURES ARE BASED ON THE FAA'S ACTION NOTICE A8150.3 DATED JULY 23, 1990.

NOTE: The FCC has mandated that the transmitter test be performed only during the first 5 minutes of each hour and last no longer than 3 audio sweeps of the ELT signal. The test must be performed a minimum of once a year.

1. Remove all interconnections between the ELT unit, the antenna, and the remote switch. Visually inspect and confirm proper seating of all connector pins. Special attention should be given to coaxial center conductor pins, which are prone to retracting into the conductor housing.
2. Remove the ELT from the mount and inspect the mount hardware. All required mounting hardware should be reinstalled and secured.
3. Gain access to the battery pack and inspect. No corrosion should be detectable. Verify that the ELT battery is an approved pack, P/N 05 07 002B. (Made of lithium poly-carbonmonoflouride cells, not alkaline. DEFT-1 ELTs are designed to operate on a 12-volt

power source. An alkaline battery pack cannot meet this specification.) Check the battery pack's expiration date.

4. Activate the ELT using an applied force. The direction for mounting and force activation is indicated on the ELT. Using a rapid forward motion coupled by a rapid reversing action should activate the DEFT-1 ELT. Verify that the ELT has been activated by the use of an airplane VHF COM receiver tuned to 121.5 MHz. (See Note 1)
5. Reinstall the ELT into its mounting tray and verify the proper direction for crash activation. Reconnect all cables. They should have some slack at each end and be properly secured to the airplane's structure for support and protection.
6. Activate the ELT by setting the switch to **ON**. A low quality AM broadcast receiver can be used to determine if energy is being radiated from the antenna. When the radio is held about 6 inches from the ELT antenna, the ELT aural tone will be heard. (See Note 2)
7. Verify that all switches are properly labeled and positioned.

Note 1: This is not a measured check; it only indicates that the G-switch is working.

Note 2: This is not a measured check, but it does provide confidence that the antenna is radiating with sufficient power to aid search and rescue. The aircraft's VHF receiver turned to 121.600 MHz may also be used. A strong ELT signal (121.5 MHz) should bleed over, and be audible.

SECTION 11 BATTERY REPLACEMENT

Authority: TSO-C91a requires that ELT batteries be replaced at 50% of their shelf life or after one hour of cumulative use. The battery replace label with the replacement date is found on the exterior of the ELT and on the replacement battery. This battery pack must be replaced every 4 years or after one hour of cumulative use.

Background: The DEFT-1 ELT transmitter is designed to operate with a 12-volt power source. The power output of the ELT is directly related to the battery voltage. To meet its performance specifications, a 12-volt replacement battery is required. From 1980 to 1996, the battery pack for DEFT ELTs consisted of 6 magnesium cells. In 1996, production of these cells ended. To continue to provide the necessary 12-volts we now use a lithium poly-carbonmonofluoride battery pack and a dummy assembly to provide the additional weight needed to maintain the original transmitter weight, maintain the unit's ability to float and to hold the active battery pack in place.

The Part Number for a replacement battery pack is 05-07-002B

CAUTIONS:

This battery pack contains lithium poly-carbonmonofluoride cells. Do not disassemble the battery pack. Do not short circuit. Lithium is flammable. Do not dispose of the battery pack in or near fire or flame.

This battery pack is approved to be carried in aircraft. It meets the 1995 International Air Transport Association (IATA) Dangerous Goods regulations that allow the transport of certain previously hazardous lithium battery products as non-hazardous after successfully completing the recommended safety testing. For additional information, contact the factory.

PROCEDURE:

Tools needed: Phillips screwdriver, size #0 or #1.

IMPORTANT:

In order to maintain the original factory weight of the DEFT ELT, a dummy cell assembly has been provided for use with the lithium battery pack. **DO NOT DISCARD!** It is needed to hold the battery pack in place within the battery compartment. Without it, the battery pack will be loose. Use of the dummy will maintain the original buoyancy of the ELT. Please refer to the drawings below for reference.

- 1 – Remove the 9 Phillips cover screws.
- 2 – Remove the cover and gasket without changing the orientation of the gasket with respect to the cover.
- 3 – The battery pack and circuit board will be visible.
- 4 – Disconnect the battery pack Molex connector from the ELT. Be careful not to dislodge its mate on the ELT. Pull by the plug not the wires.
- 5 – Remove the old battery pack from the ELT. It may be wedged in tightly.
- 6 – Insert the dummy assembly, P/N 05-09-002, as shown in the drawing below. Before inserting the battery pack, orient it as shown in the drawing below.
- 7 – Insert battery pack P/N 05-07-002B into the remaining space.
- 8 – Connect the battery to the ELT.
- 9 – Reinstall the cover and gasket using the 9 screws.
- 10 – Attach the new battery replacement label on a conspicuous place.
- 11 – Test the ELT. (See Section 5)

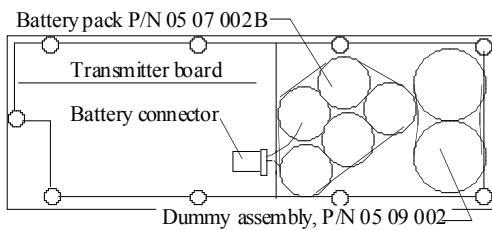
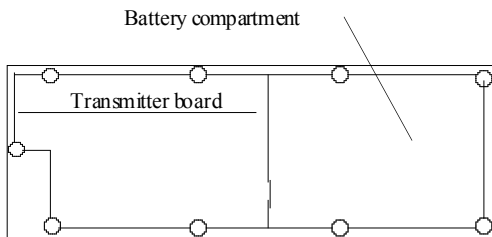

SECTION 12 REPAIRS

Should you experience any problems with your DEFT-1 ELT, contact the factory for advice. Should repairs become necessary, send the ELT to the factory. Emergency Beacon Corporation is the only authorized repair facility. Please include a note describing the problem. Emergency Beacon Corporation will evaluate the unit and contact you with a repair estimate. There is a nominal fee for this inspection.

SHIPPING INSTRUCTIONS:

- 1 – Set the ELT's toggle switch to the OFF position.
- 2 – Enclose a note describing the problem. Be sure to include your name, address and telephone number.
- 3 – Pack well and insure.

The customer pays shipping costs to and from the factory.

Send the ELT to:

Emergency Beacon Corporation, 15 River Street, New Rochelle, New York, 10801, USA

SECTION 13 SPECIFICATIONS

Carrier Frequencies	121.5 MHz and 243.0 MHz +/- 0.005% (crystal controlled)
Modulation	Swept 700 Hz (minimum from 1600 to 300 Hz at 2-3 Hz)
Peak Effective Radiated Power	160 mW at start of transmission, not less than 75 mW after 50 hours of continuous operation
Radiation	Omnidirectional
Operating Temperature Range	-20° C to +55° C
Storage (Non-operating) Temperature Range	-40° C to +71° C
Inertia Operating Characteristics	5g +2/-0 for 11 +5/-0 milliseconds
Transmitter Size (only)	9.5" H x 3.2" W x 2.8" D
Color (transmitter only)	Yellow
Total Weight	2.64 lbs.

TWO YEAR WARRANTY

Type of equipment _____
Model No. _____ Serial No. _____
Date Purchased _____ Dealer _____

PLEASE NOTE: ALL WARRANTIES ARE NULL AND VOID IF NON-FACTORY APPROVED BATTERIES ARE EVER USED IN YOUR ELT.

The Emergency Beacon Corporation instrument you have purchased is conservatively designed and was carefully inspected before shipment. Properly operated in accordance with the instructions furnished, it will provide you with trouble-free service.

If you have a problem with the transmitter, contact Emergency Beacon Corporation. If indicated, you will be instructed to send the unit to the factory. There will be no charge for labor or materials for repairs made within two years of the date of purchase.

This warranty is void if the transmitter is:

- 1 – Damaged in transit.
 - 2 – Abused in handling.
 - 3 – Repaired by unqualified persons.
- OR
- 4 – If an unapproved battery pack has been installed.

SHIPPING INSTRUCTIONS:

- 1 – Disconnect the battery connection before shipping. Ship with the battery enclosed in the unit.
- 2 – Enclose a note describing the problem. Be sure to give your name, address and phone number.
- 3 – Pack well and insure.

Customers pay all shipping costs.

Send to:

Emergency Beacon Corporation, 15 River Street, New Rochelle, New York, 10801, USA
Ph: (914) 235-9400 or 576-2700 Fax: (914) 576-7075 E-mail: emergencybeacon@sprynet.com

(cut here)

TWO YEAR WARRANTY REGISTRATION

Model No. _____ Serial No. _____
Date Purchased _____
How did you hear of this product? _____
What persuaded you to buy it? _____
Comments on performance: _____
Dealer: _____ City: _____
My name: _____
Address: _____
City: _____ State: _____ Zip: _____

Return this portion to:

Emergency Beacon Corporation
15 River Street
New Rochelle, New York 10801
USA

PLEASE NOTE: ALL WARRANTIES ARE NULL AND VOID IF NON-FACTORY APPROVED BATTERIES ARE EVER USED IN YOUR ELT.