

**BE SURE TO REGISTER
THIS ELT**

EBC-406HM

EMERGENCY LOCATOR TRANSMITTER INSTRUCTION AND MAINTENANCE MANUAL

**EMERGENCY BEACON CORPORATION
15 RIVER STREET**

NEW ROCHELLE, NY 10801

PHONE (914) 235-9400 / (914) 576-2700

FAX (914) 576-7075

800-382-0079

E-mail: emergencybeacon@verizon.net

Web: www.emergencybeaconcorp.com

**July 2009
Rev. 6**

EMERGENCY BEACON CORPORATION

THIS PAGE LEFT BLANK

EMERGENCY BEACON CORPORATION

TABLE OF CONTENTS

SECTION 1	2
GENERAL DESCRIPTION	2
SECTION 2	2
REGISTERING YOUR ELT	2
SECTION 3	2
TOGGLE SWITCH FUNCTIONS	2
SECTION 4	3
ELT INSTALLATION	3
SECTION 5	3
FINAL INSTALLATION	3
SECTION 6	3
TESTING THE ELT	3
SECTION 7	4
DESCRIPTION OF SELF-TEST MODE AND ERROR CODES	4
SECTION 8	5
OPERATING INSTRUCTIONS	5
SECTION 9	5
PERIODIC INSPECTIONS	5
SECTION 10	5
EQUIPMENT LIMITATIONS	5
SECTION 11	5
BATTERY REPLACEMENT	5
SECTION 12	6
REPAIRS	6
SECTION 13	6
EBC-406HM SPECIFICATIONS	6
National Stock Numbers for the EBC-406HM Emergency Locator Transmitter:.....	6
FIGURE 1: EBC-406HM ELT WITH BB-12M BRACKET OUTLINE WITH HOLE PATTERN.....	7
FIGURE 2: EBC-406HM ELT WITH BB-15M TRAY OUTLINE WITH HOLE PATTERN	7
GS-46 ENVIRONMENTAL QUALIFICATION FORM	8
EBC-406HM ENVIRONMENTAL QUALIFICATION FORM	8
EBC-406HM TWO YEAR WARRANTY	9

PLEASE READ. IMPORTANT!

WHEN USING IN AN EMERGENCY, REMOVE THE ELT FROM ITS MOUNT, EXIT AIRCRAFT, AND SET TOGGLE SWITCH TO THE “ON” POSITION. THE ELT’S LED SHOULD BE BLINKING.

TESTING SHOULD NOT BE DONE WITH NIGHT-VISION GOGGLES. DO TEST BEFORE START-UP!

A “3 CODE” IS COMMON WHEN TESTING WITH THE TAPE ANTENNA. THIS CAN LEAD TO AN AMBIGUOUS INTERPRETATION OF HOMER POWER. SECTION 6 DESCRIBES TEST PROCEDURES TO ELIMINATE THIS AMBIGUITY.

CERTAIN INSTALLATIONS WILL GENERATE A “4 CODE” (BAD 406 MHZ VSWR). VERIFY THAT THE ANTENNA IS WORKING BY REMOVING ELT FROM ITS MOUNT, AND RE-DOING THE SELF-TEST.

DURING NORMAL USE, KEEP THE 15-PIN D-SUB CONNECTOR DRY, AND FREE OF CONTAMINATION.

EMERGENCY BEACON CORPORATION

SECTION 1

GENERAL DESCRIPTION

The EBC-406HM is an Emergency Locator Transmitter (ELT) designed for military helicopter installation. It meets the requirements of TSO-C126 in the Automatic Portable (AP) category (see Figures 1 & 2). It is designed for mounting in the cabin of the aircraft, within reach of the pilot or co-pilot. As with all EBC ELTs, the increased survivability needs of cabin mounting have been met. The electronics and the activation system are completely encapsulated, and extra protection has been provided for the crystal. Our encapsulation method provides added protection against shock and moisture. The ELT transmits on 406.028 MHz, the civil 121.5 MHz, and the military 243.0 MHz emergency frequencies.

A unique characteristic of helicopter performance is that in the event of a loss of power, a helicopter may not necessarily go down nose first and may not have any forward motion. This may render a single axis G-switch ineffective. The EBC-406HM has two special G-switches that can sense deceleration forces from all directions, making it uniquely suited for helicopter use. These 360° spherical switches are identical to those used and proven in our original helicopter ELTs (our EBC-302HM, EBC-302VRHMJ-121.5, EBC-302VRHMJ-243.0, EBC-302VHMJ, and EBC-502HM models). They will not trigger during a hard landing.

The EBC-406HM system has an LED (on the ELT) and buzzer (on the mounting bracket/tray) to indicate ELT activation, and self-test results.

The LED and toggle switch are recessed to provide added protection against damage and inadvertent activation.

The bottom of the ELT houses a recessed D-Sub connector that mates with the mounting bracket/tray connector. The mounting bracket/tray connector is wired to a buzzer, and also wired with a G-switch loop; this loop-back enables the G-switch when properly mated to the ELT connector.

To prevent inadvertent activation, the ELT G-switches are disabled when the ELT is removed from its mount.

No external power connections are required. All indicators and controls are powered from the ELT's battery pack. Installation near the pilot eliminates the need for a wire harness and Remote Control Monitor.

SECTION 2

REGISTERING YOUR ELT

It is required that every 406 ELT be registered by the aircraft owner after installation, re-registered every two years, and re-registered if there are any changes to information provided to JSETS in a previous registration, such as telephone numbers, aircraft registration number, change of owner, ...etc.

Every 406 ELT is programmed at the factory with a unique identification code used by the Rescue Coordination Center to determine if an emergency has occurred. This identifier is called the 15-Hex ID. It is located on the front label of the ELT.

This unique identifier is stored in a database maintained by DOD/JSETS. It can be accessed to contact the owner in the event of ELT activation. Registration is free, and can even be done via the Internet. See the Airworthiness Release for further instructions on registration.

Make sure that the 15-Hex ID on the front label of the ELT is properly entered on the form. Also, enter all required information. Once you receive your registration confirmation, review it carefully. Failure to register or re-register as required every two years or to notify JSETS of any changes to the status of your 406 MHz beacon could result in penalties or unnecessary delays in search and rescue operations.

SECTION 3

TOGGLE SWITCH FUNCTIONS

The EBC-406HM must be installed in the cabin of the aircraft, within reach of the pilot or co-pilot, for easy access in an emergency.

ON position:

This position (closest to the antenna connector) manually activates the ELT. The ELT will begin radiating a distress signal on 121.500 MHz, 243.000 MHz, and within 50 seconds, will radiate an emergency coded signal on 406.028 MHz.

ARM position:

This position (center position) is the normal operating position for the ELT. When properly installed in its mount, the ELT is armed and ready to activate if an accident is sensed. When removed from its mount, the G-switch is disabled, and any mishandling will not result in activation; the ELT can still be activated by setting the toggle switch to the "ON" position.

TEST-RESET position:

This position (closest to the LED) is used to self-test, and to deactivate the ELT.

To **deactivate** the ELT, momentarily hold the toggle switch in this position (closest to LED), for about one second and quickly release. The ELT will perform a self-test, and then deactivate. Refer to **Sections 6 and 7** for self-test instructions and results.

To **self-test** the ELT, momentarily move the handle from the center position to the "TEST-RESET" position; hold for about one second and quickly release. The ELT will perform a self-test and then deactivate. Refer to **Sections 6 and 7** for self-test instructions and results.

It is recommended that the homer signal be monitored on a radio tuned to 121.500 MHz.

DISABLING THE AUTOMATIC ACTIVATION FEATURE

The ELT G-switch is disabled when the ELT is removed from its mount, and enabled ONLY when the ELT is installed and properly mated to its mounting bracket/tray connector. The mounting bracket/tray connector has a loop-back installed at the factory. The loop-back is checked by the self-test.

A "2 code" indicates a disabled G-switch.

EMERGENCY BEACON CORPORATION

SECTION 4

ELT INSTALLATION

The EBC-406HM can be installed with the BB-12M mounting bracket, or the BB-15M mounting tray. The choice is determined by the available clearance at the mounting location.

1. The EBC-406HM can be installed in any convenient location within the cockpit / cabin area of the aircraft, preferably within reach of the pilot or copilot. The transmitter controls must be accessible.
2. For best performance install so that the antenna is visible through a window when viewed from the outside of the aircraft.
3. The antenna should be at least one inch away from any metal window post.
4. The mounting bracket/tray supplied with the ELT must be securely attached to the aircraft. One way to judge the security of the installation is to apply a force to the mounting bracket/tray of about 100 lbs, and see that it does not move more than $\frac{1}{2}$ of 1 inch. Greater movement would suggest that the beacon mounting is not firm enough, and establishes a possible false alarm situation in conditions of severe vibration or turbulence. In many cases, various military organizations have come up with suggested mounting areas that have been thoroughly researched and found to be preferred locations for specific aircraft.
5. Use the BB-12M bracket or BB-15M tray as a template to mark out the holes needed for installation, or refer to Figures 2 and 3 for dimensions. After selecting a suitable location, drill and mount the EBC-406HM mounting bracket or tray.
6. When installing the BB-12M mounting bracket, leave a minimum of 3 inches of clearance on the latch side of the BB-12M mounting bracket (measured from the side of the bracket and any obstruction) to allow for latch operation.
7. Do not install to thin unsupported skin or fabric.

SECTION 5

FINAL INSTALLATION

Perform a self-test, and a full functional check, when installing the ELT in its mount for the first time, after battery replacement, or according to maintenance schedules. **Refer to Sections 6 and 7 for details.**

Securing the ELT in the BB-12M

Gently install the ELT into the mounting bracket until the ELT is fully seated. Do not use excessive force. It may be necessary to adjust ELT position (front to back, and left to right) to properly mate the connectors. Close the latch by lifting the latch spring up, and hooking it on to the top edge of the ELT. Depress lever until the latch lever locks into place. Verify that ELT is off, and that the toggle switch is in the center, "ARM" position.

Securing the ELT in the BB-15M

The connector on the BB-15M tray floats to permit easy installation and removal of the ELT. When installing the ELT, slide the floating connector forward, and insert the ELT into the mounting tray until the ELT is fully seated. Slide the ELT back until it is resting on the tray felt. Close the latch by bringing the

two ends of the latch strap as close as possible to each other. Secure latch spring onto catch, and depress lever until the lever locks into place. Verify that ELT is off, and that the toggle switch is in the center, "ARM" position.

SECTION 6

TESTING THE ELT

This section describes how to test the ELT to verify that it is radiating usable signals on 121.5 MHz, and 406.028 MHz, and that the two G-switches are operational. LED and buzzer operation will be verified, and the loop-back will be checked.

Perform all or some of these tests when installing the ELT for the first time, every time the ELT is reinstalled in its mount, whenever the battery pack is replaced, or according to maintenance schedules.

To facilitate testing, EBC recommends the use of the following items:

1. A 50-Ohm load attached to the ELT BNC connector to test power output. If not available, then testing without one is permissible. Allow at least 1 minute between self-tests.
2. A Male 15-pin D-connector with jumper from pin 1 to pin 11 to test G-switches.
3. A COM radio tuned to 121.500 MHz or 121.700 MHz, depending on what test method is used.

SELF-TEST:

The self-test checks the loop-back, and verifies that the ELT is sending usable signals on 121.500 MHz and 406.028 MHz to the antenna. Always perform a self-test when the ELT is reinstalled in its mount, the battery pack is replaced, or according to maintenance schedules. Section 7 describes error codes and their meanings.

IMPORTANT:

TEST CONDITIONS WILL DETERMINE ERROR CODES. USE THE ERROR CODE MATRIX CHART ON THE NEXT PAGE TO DETERMINE WHETHER THE ELT HAS PASSED OR FAILED THE SELF-TEST.

AN ERROR CODE OTHER THAN THOSE LISTED IN THE CHART IS CONSIDERED A FAILURE.

POWER OUTPUT CHECK:

NOTE: A "3 code" (low 121.5 MHz power) is common when testing with the tape antenna attached. This can lead to an ambiguous interpretation of homer power. Verify 121.5 MHz power by using one of the three methods described below.

Method 1

1. Tune COM radio to 121.700 MHz. If a COM is not available, an inexpensive AM radio can be placed near the ELT tape antenna.
2. Perform self-test with tape antenna attached. Three ELT audio sweeps **SHOULD BE HEARD** on the COM or AM radio (This is not a measured check. It indicates that the ELT is radiating a sufficient signal to aid search and rescue). The ELT will perform a self-test, return the results of the test via the LED/buzzer, and then deactivate.

EMERGENCY BEACON CORPORATION

Method 2

1. Tune COM radio to 121.500 MHz.
2. Remove the tape antenna, and attach a 50-Ohm load.
3. Perform a self-test. Three ELT audio sweeps **SHOULD BE HEARD** on the COM. The ELT will perform a self-test, return the results of the test via the LED/buzzer, and then deactivate.

A “3 CODE” USING THIS METHOD IS A FAILURE!

Method 3

1. Tune COM radio to 121.500 MHz.
2. Remove the tape antenna.
3. Perform a self-test without anything attached to the ELT antenna connector. Three ELT audio sweeps **SHOULD BE HEARD** on the COM. The ELT will perform a self-test, return the results of the test via the LED/buzzer, then deactivate.

A “3 CODE” USING THIS METHOD IS A FAILURE!

EBC-406HM ERROR CODE MATRIX CHART

TEST CONDITION	COMMON ERROR CODES
ELT IN ITS MOUNT, OR WITH LOOP-BACK JUMPER ATTACHED:	
Tape antenna connected	3 code, 4 code
50-Ohm load connected	No error codes
With nothing connected to ELT antenna connector	4 code
ELT OUT OF ITS MOUNT, OR WITHOUT LOOP-BACK JUMPER ATTACHED:	
Tape antenna connected	2 code, 3 code, 4 code
50-Ohm load connected	2 code
With nothing connected to ELT antenna connector	2 code, 4 code

LED, BUZZER CHECK:

The LED should and buzzer should indicate when the ELT is transmitting and when a self-test is performed.

LOOP-BACK CHECK:

The loop-back is okay if a “2 code” is not returned, with the ELT installed in its mount.

G-SWITCH OPERATION:

To verify that the two G-switches are operational, it will be necessary to fabricate a jumper:

Method 1

Use a D-sub 15-pin male connector, and solder a wire between pin 1 and pin 4. Install mating connector to ELT connector.

Method 2

Remove ELT from mount and place a #24 AWG jumper between pins 1 and 4 of the ELT D-sub connector.

Verify that both G-switches are operational by performing two activations. Tune VHF COM radio to 121.500 MHz.

Verify that the ELT’s toggle switch is set to the “**ARM**” position

1. Remove the tape antenna and attach a 50-Ohm load. If not available, test without anything attached to the antenna terminal. Allow at least 1 minute between tests.

2. Test for horizontal activation by holding the ELT at arms length with ELT in a vertical position. Swing the ELT around your body in the horizontal plane, (like a forehand tennis swing), as fast as possible. This may require a few tries since a great deal of force will be required to simulate a crash. The distinctive ELT audio sweep should be heard over the radio, and the LED should be blinking. This is not a precise check; it only indicates that the G-switch is working. Reset the ELT.

3. Test for vertical activation, by holding the ELT at arms length with the antenna side pointed toward the horizon. Swing the ELT around your body as fast as possible. The distinctive ELT audio sweep should be heard over the radio, and the LED should be blinking. This is not a precise check; it only indicates that the G-switch is working. Reset the ELT.

4. Remove the test jumper, reattach the tape antenna, and install the ELT into its mount. Secure in place by closing latch.

SECTION 7

DESCRIPTION OF SELF-TEST MODE AND ERROR CODES

Set the ELT’s toggle switch to the spring loaded, “**TEST-RESET**” position for 1 second and quickly release. The self-test event occurs in the following manner:

The ELT energizes its LED/buzzer for about 1 second.

Three beacon audio sweeps are transmitted on 121.500 MHz.

One, 406.028 MHz self-test burst is transmitted.

During these transmissions, the ELT will perform a number of internal tests on its data and electronics.

If the ELT has passed all tests, the LED/buzzer will flash/beep for one second, and then de-energize.

If the ELT has not passed any or all of its tests, the LED/buzzer will flash/beep for one second, and de-energize for _ second. Following this, error codes are indicated by one or more error indications of the LED/buzzer.

The cadence of these on-off intervals will cause the LED/buzzer to flash/beep for _ of a second interval followed by _ of a second de-energized interval.

In the event that the ELT needs to signal multiple error codes, several LED/buzzer on-off sequences will follow, one after the other, and each sequence separated by an LED/buzzer de-energized interval of one second.

A self-test pass is indicated by a 1-second flash/beep.

EMERGENCY BEACON CORPORATION

SELF-TEST ERROR CODES AND MEANINGS	
ERROR CODE	MEANING
2 code.	Missing G-switch loop back: Can indicate that the ELT is not fully seated in its mount, or the mating connector is not properly attached. It can also indicate a missing jumper from pin 1 to pin 11. This condition renders the G-switch inoperative.
3 code.	Bad 121.500 MHz RF output power: Can mean that the homer signal on 121.5 MHz is not operating. This error code is normal with the tape blade antenna. See Section 6 for test recommendations.
4 code.	Bad 406 MHz RF VSWR: Can indicate an antenna close to other objects.
5 code.	Low 406 RF power output: Can indicate a low voltage battery, or a defective 406 power amplifier.
6 code.	Bad EEPROM data: Can indicate a hardware or software fault. ELT will only transmit on 121.5 & 243 MHz.
7 code.	Bad RAM: Can indicate a hardware or software fault. ELT will only transmit on 121.5 & 243 MHz.

SECTION 8 OPERATING INSTRUCTIONS

The EBC-406HM is for aviation emergency use only. In an accident with sufficient G-forces, the ELT is automatically activated.

When using in an emergency, remove ELT from its mount, exit the aircraft, and set the toggle switch to the "ON" position.

Setting the ELT's toggle switch to the "ON" position manually activates the ELT.

When the ELT is automatically or manually activated, there is a 1-second delay before the 121.500 MHz / 243.00 MHz homer transmitter activates. This is followed approximately 50 seconds later by the 406.028 MHz burst.

REMOVING THE ELT FROM THE BB-12M MOUNTING BRACKET

Remove the ELT from its mounting bracket by simultaneously using the thumb to push on the snap lock, and the forefinger to pull up on the latch lever. Move the latch out of the way, and pull the ELT out by the lanyard.

REMOVING THE ELT FROM THE BB-15M MOUNTING TRAY

Remove the ELT from its mounting tray by simultaneously using the thumb to push on the snap lock, and the forefinger to pull up on the latch lever. Compress the strap against the ELT so that the latch clears the keeper. Move the straps out of the way, and pull out the ELT.

Place the ELT on high ground with the antenna in a vertical position. For longest operating life, if using at temperatures

below -20° C, keep the transmitter inside your jacket with the antenna exposed.

SECTION 9 PERIODIC INSPECTIONS

This inspection notice is based on FAA, AC 43.13-1B CHG 1, dated 9/27/01.

NOTE: The FCC has mandated that the transmitter test be performed only during the first 5 minutes of each hour and last no longer than 3 audio sweeps of the ELT signal. The test must be performed a minimum of once a year.

1. Remove the ELT Tape antenna. Visually inspect and confirm proper seating of all BNC connector pins at the antenna end, and at the ELT end. Special attention should be given to coaxial center conductor pin, which may retract into the conductor housing. Check for corrosion, and any obvious signs of wear.
2. Remove the ELT from its mount and inspect D-Sub connectors for corrosion, and any obvious signs of damage, such as bent or missing pins. Inspect the mounting hardware for stability. All required mounting hardware should be reinstalled and secured.
3. Inspect the battery pack. No corrosion should be detectable. Verify that the ELT battery connectors are fully mated with no gap between them. Verify that the battery is an approved pack, GS-46, manufactured by Emergency Beacon Corporation. Check the battery pack's expiration date.
4. Perform full functional tests on the ELT as described in Section

SECTION 10 EQUIPMENT LIMITATIONS

The conditions and tests required for TSO approval of this article are minimum performance standards. It is the responsibility of those desiring to install this article on a specific type or class of aircraft to determine that the aircraft installation conditions are within the TSO standards. The article may be installed only if further evaluation by the applicant documents an acceptable installation and it is approved by the Administrator.

This equipment must be installed according to the recommendations outlined in this manual. Only Emergency Beacon Corporation TSO approved parts are to be used. Substitution of other components will void the warranty. Any deviation may result in failure of the equipment to operate properly.

SECTION 11 BATTERY REPLACEMENT

FAR 91.207(c) requires that the battery in the ELT be replaced in accordance with the replacement date marked on the ELT or when the transmitter has been in use for more than one cumulative hour. The battery replace label is found on the exterior of the ELT and on the battery. The battery pack must be replaced every 5 years or after one hour of cumulative use. The battery should not be stored where the ambient temperature is above 80°C, or below -40°C.

WARNING: Use only battery, P/N GS-46. The ELT will not meet the requirements of TSO-C126 if used with another battery. GS-46 battery packs are available from Emergency Beacon Corporation (EBC) and its dealers.

EMERGENCY BEACON CORPORATION

BATTERY INSTALLATION PROCEDURE:

1. Verify that the ELT is off, and remove it from its mount.
2. Unscrew the 4 back cover screws and remove cover.
3. Observe the manner in which the current battery is situated within the ELT. The new battery must be installed in the same physical orientation as the current battery.
4. Remove the plastic U strip spacer.
5. Grasp battery connectors, and pull apart. Do not pull on the wires or they may be damaged! The battery pack is a Class 9 hazardous material. Dispose of according to local regulations.
6. Check for corrosion on the battery connector, the BNC connector, and D-Sub connector. Clean as required.
7. Insert new battery with label facing up, and remove "Replace Battery By" label. Tightly mate connectors.
8. Install plastic U strip spacer.
9. Install the "Replace Battery By" label, on the side of the ELT.
10. Reinstall back cover, and antenna.
11. Perform tests as per Section 6. Install ELT into mount.

The Part Number for a replacement battery pack is GS-46.

CAUTIONS:

This battery pack is comprised of 3 lithium manganese dioxide cells. Do not disassemble the battery pack. Do not short circuit. Lithium is flammable. Do not dispose of the battery pack in or near fire or flame.

The conditions and tests required for this TSO approval of this battery are minimum performance standards. It is the responsibility of those desiring to install this battery in a specific class of aircraft to determine that the aircraft installation conditions are within the TSO standards. The battery may be installed only if further evaluation by the applicant documents an acceptable installation and is approved by the administrator. Lithium battery safety concerns include the possibility of fire, venting violently, and venting toxic gases.

Battery Specifications:

System: Non-rechargeable Lithium
Manganese Dioxide
Nominal Open Circuit Voltage 9.8 VDC, Red lead positive
Total Lithium Content 10.2 grams
Nominal Size H = 2.53" W = 1.42" L = 4.14"
Nominal Weight Approximately 1.2 lbs.
Certification TSO-C142

SECTION 12

REPAIRS

Should you experience any problems with your ELT, contact the factory for advice. Should repairs become necessary, remove the battery. Send the ELT, less battery, to the factory. EBC is the only authorized repair facility. Please include a note describing the problem. EBC will evaluate the unit and contact you with a repair estimate. There is a nominal fee for this inspection unless the ELT is under warranty.

SHIPPING INSTRUCTIONS:

- 1 – Send the ELT without battery.
- 2 – Enclose a note describing the problem, and if a new battery is needed. Include your name, address and telephone number.
- 3 – Pack well and insure.

The customer pays shipping costs to and from the factory.

Send the ELT to:

Emergency Beacon Corporation,
15 River Street
New Rochelle, New York, 10801, USA

SECTION 13

EBC-406HM SPECIFICATIONS

Operating Frequencies: 406.028 MHz, 121.500 MHz,
and 243.000 MHz
Modulation 406 MHz: Biphase L (16KOG1D)
Modulation 121.500 MHz: Swept tone 1600 Hz to
300 Hz, 2-4 times/second
Output Power on 406 MHz: 5W for 24 hours at -20 C
Output Power on 121.5 MHz: 50 mW min for 50 hours at -20 C
Operating Temperature: -20 C to +55 C
Battery Type: Li-MnO₂
Useful Battery Life: 5 years or 1 hour of cumulative use
Automatic Activation: True 360° spherical 6 axis
G-switch system 5-7 G's
Altitude: 50,000 ft
Decompression: 8000 ft to 50,000 ft
Over Pressure: -15,000 ft
Humidity: 95% for 144 hours
Shock Performance: 500 Gs for 4ms; 100 Gs for 100ms
Vibration: Withstands 10 Gs
Immersion: 24 hours in salt water
Message Protocols: Aviation User Protocol,
Serialized Aviation User Protocol
Activation Alerts LED and buzzer
Input Power No Aircraft Power Required

PHYSICAL FEATURES:

Size (ELT): H = 6.7" W = 2.9" D = 2.5"
Total Weight: 2.75 lbs.
Case Material: Aluminum
Finish: Flat Black

National Stock Numbers for the EBC-406HM Emergency Locator Transmitter:

- 5821-01-560-7879 - EBC 406HM with BB-12M Mounting Bracket.
- 6135-01-560-7877 - GS-46 Lithium Battery Pack
- 5985-01-560-7878 - Antenna, ANT-406T
- 5340-01-560-7876 - BB-12M Mounting Bracket (Standard Bracket)
- 5340-01-564-5623 - BB-15M Mounting Tray (Alternate Bracket)

EMERGENCY BEACON CORPORATION

FIGURE 1: EBC-406HM ELT WITH BB-12M BRACKET OUTLINE WITH HOLE PATTERN

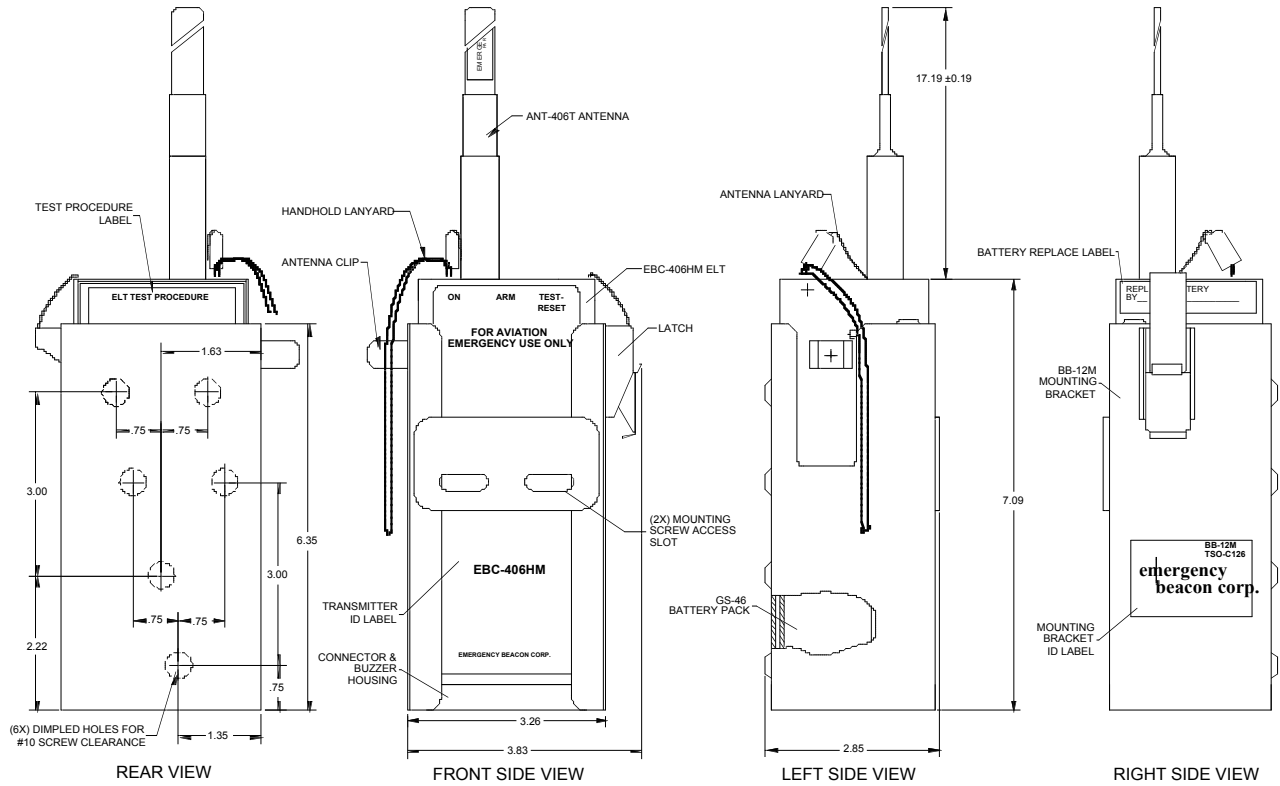
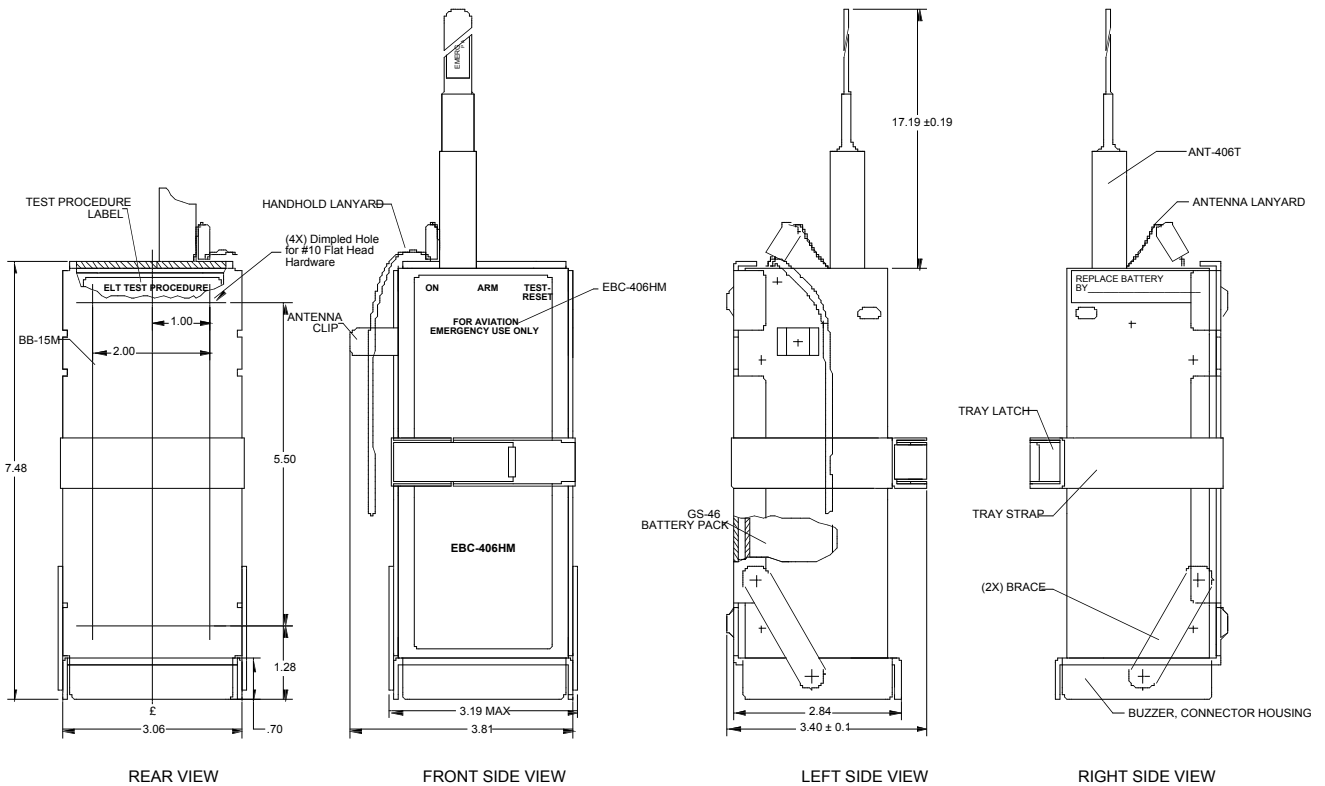

FIGURE 2: EBC-406HM ELT WITH BB-15M TRAY OUTLINE WITH HOLE PATTERN



EMERGENCY BEACON CORPORATION

GS-46 ENVIRONMENTAL QUALIFICATION FORM

APPLICABLE SPECIFICATIONS: RTCA DO-227, RTCA DO-204, RTCA DO-160C
 ENVIORNENTAL CATEGORY: 227/227/227/227/204/204/XXXXXXX

TEST CONDITIONS	Section DO-160C	Paragraph	Category
Survival Low / High Temperature Cycle	-	2.3.3	Per DO-227
Altitude	-	2.3.4	Per DO-227
Decompression	-	2.3.5	Per DO-227
Humidity	-	2.3.6	Per DO-227
Shock	-	2.3.4.1	Per DO-204
Vibration	8.0	2.3.5	Per DO-160C/204
Explosion Proofness	9.0	-	X
Waterproofness	10.0	-	X
Fluids Susceptibility	11.0	-	X
Sand and Dust	12.0	-	X
Fungus Resistance	13.0	-	X
Salt Spray	14.2	-	X
Magnetic Effect	15.0	-	X
Power Input	16.0	-	X
Voltage Spike	17.0	-	X
Audio Freq. Conducted Susceptibility	18.0	-	X
Induced Signal Susceptibility	19.0	-	X
R.F. Susceptibility	20.0	-	X
Emission of R.F. Energy	21.0	-	X
Lightning Induced Transient Susceptibility.	22.0	-	X
Lightning Direct Effects	23.0	-	X
Icing	24.0	-	X

EBC-406HM ENVIRONMENTAL QUALIFICATION FORM

Nomenclature: 406 / 121.5 / 243.0MHz Emergency Locator Transmitter.
Part Numbers: EBC-406HM, BB-12M, GS-46 **TSO Number:** C126
Other Applicable Specifications: RTCA DO-204
Manufacturer: Emergency Beacon Corporation **Address:** 15 River Street, New Rochelle, New York
Revision of DO-160: C and D **Tests started:** 5/20/06. **Tests completed:** 2/25/07.

ENVIRONMENTAL CATEGORIES: D1XBC(204)(204)XRFXXSXXXZ(204)X(A1C1)XXA

CONDITIONS	SECTION	DESCRIPTION OF TESTS CONDUCTED
TEMPERATURE AND ALTITUDE	4.0	EQUIPMENT TESTED TO CATEGORY D1
OPERATING LOW TEMPERATURE	4.5.1	EQUIPMENT TESTED TO CATEGORY D1
OPERATING HIGH TEMPERATURE	4.5.2 & 4.5.3	EQUIPMENT TESTED TO CATEGORY D1
IN-FLIGHT LOSS OF COOLING	4.5.4	NOT APPLICABLE
ALTITUDE	4.6.1	EQUIPMENT TESTED TO CATEGORY D1
DECOMPRESSION	4.6.2	EQUIPMENT TESTED TO CATEGORY D1
OVERPRESSURE	4.6.3	EQUIPMENT TESTED TO 170 kPa abs.
TEMPERATURE VARIATION	5.0	EQUIPMENT TESTED TO CATEGORY B
HUMIDITY	6.0	EQUIPMENT TESTED TO CATEGORY C
OPERATIONAL SHOCK	7.0	EQUIPMENT TESTED TO CATEGORY (204)
OPERATIONAL CRASH SAFETY	7.0	EQUIPMENT TESTED TO CATEGORY (204)
VIBRATION	8.0	EQUIPMENT TESTED TO CATEGORY (204)
EXPLOSION	9.0	NOT APPLICABLE
WATERPROOFNESS	10.0	EQUIPMENT TESTED TO CATEGORY R
FLUIDS SUSCEPTIBILITY (salt water)	11.0	EQUIPMENT TESTED TO CATEGORY F
SAND AND DUST	12.0	NOT APPLICABLE
FUNGUS	13.0	NOT APPLICABLE
SALT SPRAY	14.0	EQUIPMENT TESTED TO CATEGORY S
MAGNETIC EFFECT	15.0	NOT APPLICABLE
POWER INPUT	16.0	NOT APPLICABLE
VOLTAGE SPIKE	17.0	NOT APPLICABLE
AUDIO FREQUENCY SUSCEPTIBILITY	18.0	NOT APPLICABLE
INDUCED SIGNAL SUSCEPTIBILITY	19.0	EQUIPMENT TESTED TO CATEGORY Z
RADIO FREQUENCY SUSCEPTIBILITY	20.0	EQUIPMENT TESTED TO CATEGORY (204)
RADIO FREQUENCY EMISSION	21.0	NOT APPLICABLE
LIGHTNING INDUCED TRANSIENT SUSCEPTIBILITY	22.0	EQUIPMENT TESTED TO CATEGORY A1C1
LIGHTNING DIRECT EFFECTS	23.0	NOT APPLICABLE
ICING	24.0	NOT APPLICABLE
ELECTROSTATIC DISCHARGE	25.0 (DO-160D)	EQUIPMENT TESTED TO CATEGORY A

OTHER DO-204 ENVIRONMENTAL TESTS PASSED

CONDITIONS	SECTION	DESCRIPTION OF TESTS CONDUCTED
IMPACT PENETRATION	2.3.4.2	55 LBS IMPACT FROM 6 INCHES TEST
CRUSH	2.3.4.3	1000 LBS APPLIED FORCE CRUSH TEST
FLAME	2.3.7.1	15 SECOND FLAME EXPOSURE TEST
POST CRASH IMMERSION	2.3.9.4	1 METER SALT WATER IMMERSION TEST
OTHER ELECTRONIC TESTS	2.3.2 THRU 2.3.2.6	LOW-TEMP. LIFE, HIGH TEMP., TEMP. GRADIENT/ FREQ. STABILITY, VSWR THERMAL SHOCK, SELF TEST
LONG TERM FREQUENCY DRIFT	2.4.2.1.4	IDENTIFIED AS PER RF OSC. MFG. DATA*

* Not tested but identified as meeting requirement from manufacturer's specifications.

EMERGENCY BEACON CORPORATION

EBC-406HM TWO YEAR WARRANTY

FOR YOUR RECORDS:

Type of Equipment: _____

Model No. _____ Serial No. _____

Date Purchased: _____ Dealer: _____

PLEASE NOTE: ALL WARRANTIES ARE NULL AND VOID IF NON-FACTORY APPROVED BATTERIES ARE EVER USED IN YOUR ELT.

The EMERGENCY BEACON CORPORATION instrument you purchased is conservatively designed and was carefully inspected before shipment. Properly operated in accordance with the instructions furnished, it will provide you with trouble-free service. Should repairs become necessary, write or call EMERGENCY BEACON CORPORATION describing symptoms of faulty operation. Instructions will be sent to you for obtaining service, if factory judges necessary, authorization for shipment will be given to you, including removing the battery and sending ELT without battery pack. Do not ship without first obtaining this authorization. Pack well and insure when shipping. Repairs will be made without charge for materials and labor within two years from date of warranty registration. Transportation charges both ways are to be borne by the customer. Beyond this warranty period fair charges will be made for service using factory approved new parts. This warranty is void if:

- 1- Damaged in transit.
- 2- Abused in any way.
- 3- Repair is attempted by persons not authorized by EBC.
- 4- Unapproved battery is installed.

EMERGENCY BEACON CORPORATION (EBC),
15 River Street, New Rochelle, New York USA 10801
Phone: (914) 235-9400; (914) 576-2700; FAX: (914) 576-7075.

(CUT HERE AND RETURN TO FACTORY)

TWO YEAR WARRANTY REGISTRATION

Model No: _____ Serial No: _____

Date Purchased: _____

How did you hear of this product? _____

What persuaded you to purchase it? _____

Dealer: _____ City: _____

My name: _____

Address: _____

City: _____ State: _____ Zip: _____

Return this portion to: EMERGENCY BEACON CORPORATION
15 RIVER ST.
NEW ROCHELLE, NY 10801, USA